

# 8810 Series



## Applications

All underwater mateable equipments.

## Standards



## Description

- The 8810 range is designed to be wet or underwater mated and can be used at depths down to 3000 meters. The metal body shells feature rugged, square cut coupling threads to enhance the 8810's suitability for repeated coupling and uncoupling in severe environmental conditions. Connector front faces can withstand either 150 or 300 bars uncoupled wet pressure. Underwater sealing caps are available for use on connectors power on or for long term immersion.

## Characteristics

### Mechanical

- Pressure resistance : working pressure (Mated or non mated connectors)
  - Shell sizes 1, 2, 3, 4, 7
    - Fitted with cable gland endbell : 300 bar
    - Fitted with longitudinally sealed : 300 bar endbell
  - Shell sizes 5, 6
    - Fitted with all endbell types : 150 bar
- Endurance 500 mating/unmating operations
- Metal shell\* : Nickel aluminum bronze
- Insulators : Molded rubber
- Contacts : Gold plated copper alloy
- Band and buckles stainless steel 316L
- Stainless steel 316L, inconel, monel, titanium, aluminum... available on request

### Operational

- Working temperature
  - Ambient : -30°C + 70°C
  - Subsea : -3°C + 40°C
- Shocks 75 g - 11 ms (3 axis)
  - Shell size 1, 2, 3, 4, 7
- Vibrations
  - 0.1 Hz to 1 Hz (25 mm amplitude peak to peak 50)
  - 1 Hz to 5 Hz (0.1 g acceleration)
  - 5 Hz to 22 Hz (1 mm amplitude peak to peak 2)
  - 22 Hz to 50 Hz (2 g acceleration)
- Underwater explosion shock tests (heavy weight high impact)
  - Tested in accordance with, Specification MIL-S 901C (NAVY) and HI
  - Test procedure n° HT 0458-TP-1 Original issue
  - Grade : «A»
  - Equipment classification : Hull Mounted external
  - Class : «I»
  - Test classification : Heavy Weight
  - Type : «A»
  - Tested for the US Navy (NCSC)

### Electrical

Layouts	Maximum current rating per contact (A)	Maximum bundle current capacity per contact (A)
4 cts # 20	7.5	7.5
7 cts # 20	7.5	6.5
12 cts # 20	7.5	5.5
19 cts # 20	7.5	4.5
38 cts # 20	7.5	3.5
4 cts # 16	15	14
12 cts # 16	15	12
37 cts # 16	15	6.5
66 cts # 16	15	5
1 Ø 7 mm	100	100
4 # 8	45	35
1 Ø 18 mm	400	400
4 Ø 10+2#8	150 + 45	150 + 45

Layouts		Contacts sizes	Test voltage (Vrms)	Working voltage in external wet conditions ambient (Vrms)	Working voltage after subsea mating conditions complied (Vrms)
Shell size	Number of contacts				
1	4	# 20	2500	500	220
2	7	# 20	2500	500	220
	4	# 16	2500	500	220
3	1	Ø 7 mm	3750	750	750
	12	# 20	2500	500	220
4	19	# 20	2500	500	220
	12	# 16	2500	500	220
	4	# 8	3750	750	360
5	37	# 16	2500	500	220
	1	Ø 18 mm	7500	1500	1500
6	68	# 16	2500	500	220
	4	Ø 10 mm	3750	750	360
7	38	# 20	2500	500	220

\* After 5 mating/demating operations in clear water and suitable lubricate insulator (with silicone grease)

# 8810 Series



## Ordering information

### Standard connectors

shell size	Nbr. of contacts	plug (36H)	jam nut receptacle (10H)	cable connecting receptacle (11H)
1	4	8810-36H-1-04SA	8810-10H-1-04PA	8810-11H-1-04PA
2	7	8810-36H-2-07SA	8810-10H-2-07PA	8810-11H-2-07PA
2	4	8810-36H-2-04S	8810-10H-2-04P	8810-11H-2-04P
2	1	8810-36H-2-01SA	8810-10H-2-01PA	8810-11H-2-01PA
3	12	8810-36H-3-12SA	8810-10H-3-12PA	8810-11H-3-12PA
4	19	8810-36H-4-19SA	8810-10H-4-19PA	8810-11H-4-19PA
4	12	8810-36H-4-12SA	8810-10H-4-12PA	8810-11H-4-12PA
4	4	8810-36H-4-04SA	8810-10H-4-04PA	8810-11H-4-04PA
7	38	8810-36H-7-38SA	8810-10H-7-38PA	8810-11H-7-38PA
5	37	8810-36H-5-37SA	8810-10H-5-37PA	8810-11H-5-37PA
5	1	8810-36H-5-01SA	8810-10H-5-01PA	8810-11H-5-01PA
6	68	8810-36H-6-68SA	8810-10H-6-68SA	8810-11H-6-68PA
6	4 + 2	8810-36H-6-04SA	8810-10H-6-04PA	8810-11H-6-04PA

Note : Extra keyways x, y, z... are available on special request





### Custom design receptacles

shell size	Nbr. of contacts	inverse pressure receptacle (12H)	thrubulkhead receptacle (14H)	square flange receptacle (15H)
1	4	8810-12H-1-04PA	8810-14H-1-04PA	8810-15H-1-04P
2	7	8810-12H-2-07PA	8810-14H-2-07PA	8810-15H-2-07P
2	4	8810-12H-2-04P	8810-14H-2-04PA	8810-15H-2-04P
2	1	8810-12H-2-01PA	8810-14H-2-01PA	8810-15H-2-01P
3	12	8810-12H-3-12PA	8810-14H-3-12PA	8810-15H-3-12P
4	19	8810-12H-4-19PA	8810-14H-4-19PA	8810-15H-4-19P
4	12	8810-12H-4-12P	8810-14H-4-12PA	8810-15H-4-12P
4	4	8810-12H-4-04PA	8810-14H-4-04PA	8810-15H-4-04P
7	38	8810-12H-7-38P	8810-14H-7-38P	8810-15H-7-38PA
5	37	8810-12H-5-37P	8810-14H-5-37PA	8810-15H-5-37P
5	1	8810-12H-5-01P	8810-14H-5-01PA	8810-15H-5-01P
6	68	8810-12H-6-68P	8810-14H-6-68PA	8810-15H-6-68P
6	4 + 2	8810-12H-6-04P	8810-14H-6-04PA	8810-15H-6-04P

# 8810 Series

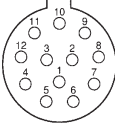
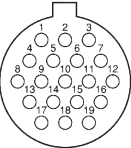
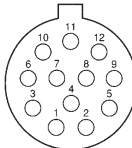
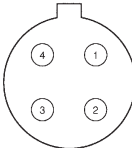
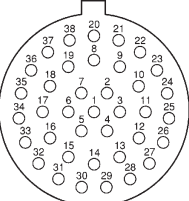
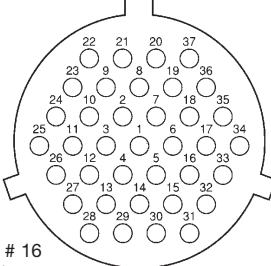
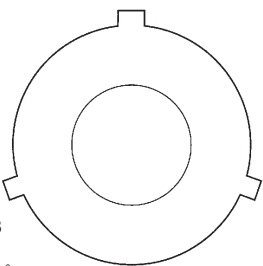
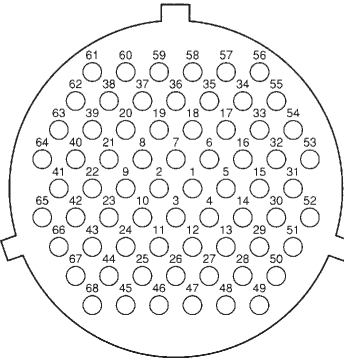
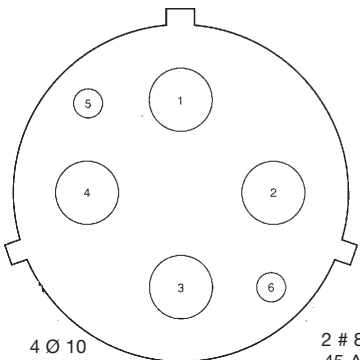

## Contact layouts (Plug back face view)

layouts		size 20 contacts	size 16 contacts	power contacts
shell size	number of contacts	contact diameter : 1.0 mm / 0.039 wire size max : 0.93 mm <sup>2</sup> current rating per contact : 7.5A max	contact diameter : 1.57 mm / 0.062 wire size max : 1.34 mm <sup>2</sup> current rating per contact : 15A max.	contact diameter : see below wire size max : see below current rating : see below
<b>1</b>	<b>4</b>	4 # 20 0.93 mm <sup>2</sup> 		
<b>2</b>	<b>7</b> <b>4</b> <b>1</b>	7 # 20 0.93 mm <sup>2</sup> 	4 # 16 1.34 mm <sup>2</sup> 	1 Ø 7 100 A 16 mm <sup>2</sup> 
<b>3</b>	<b>12</b>	12 # 20 0.93 mm <sup>2</sup> 		
<b>4</b>	<b>19</b> <b>12</b> <b>4</b>	19 # 20 0.93 mm <sup>2</sup> 	12 # 16 1.34 mm <sup>2</sup> 	4 # 8 45 A per contact 4 mm <sup>2</sup> 
<b>7</b>	<b>38</b>	38 # 20 0.93 mm <sup>2</sup> 		
<b>5</b>	<b>37</b> <b>1</b>		37 # 16 1.34 mm <sup>2</sup> 	1 Ø 18 400 A 185 mm <sup>2</sup> 
<b>6</b>	<b>68</b> <b>4</b>		68 # 16 1.34 mm <sup>2</sup> 	4 Ø 10 150 A per contact 70 mm <sup>2</sup>  2 # 8 45 A 45 mm <sup>2</sup>

# 8810 Series



## Dimensions

### Plugs (series 36H)

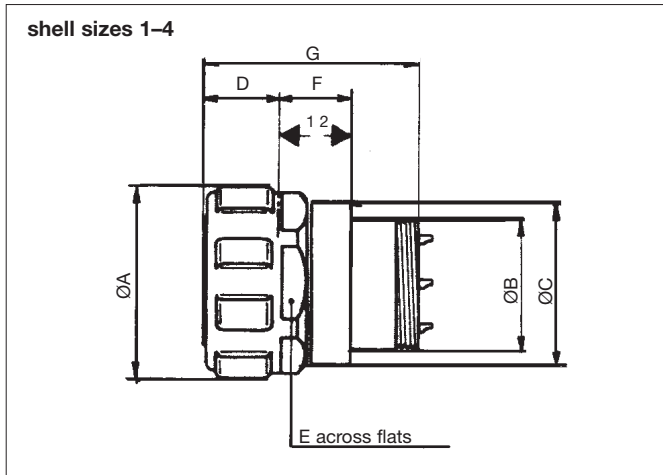

shell size	1	2	3	4
<b>A Max</b>	30.00 1.181	33.50 1.319	39.00 1.535	43.50 1.713
<b>B iso</b>	16.8x0.5	20x0.75	25.5x0.75	30x0.75
<b>C Max</b>	24.20 .953	27.70 1.091	33.20 1.307	37.70 1.484
<b>E Max</b>	26 1.024	29 1.142	34 1.339	38 1.496
<b>D Max</b>	17.30 .681	17.30 .681	18.30 .720	19.30 .760
<b>F Max</b>	16.80 .661	16.80 .661	15.80 .622	14.80 .583
<b>G Max</b>	50.10 1.972	50.10 1.972	50.10 1.972	50.10 1.972

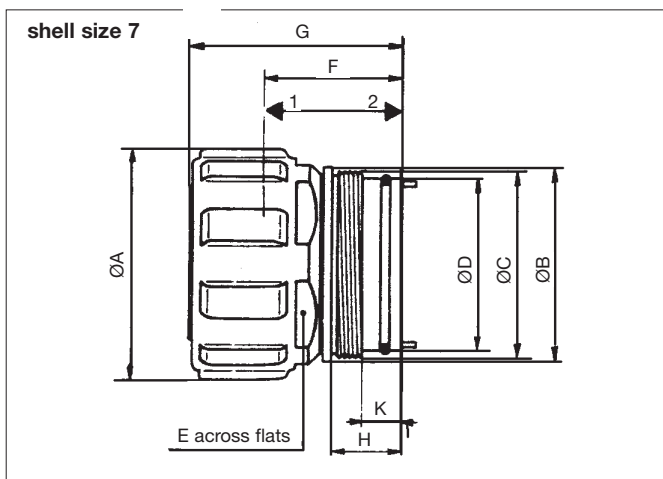

shell size	7
<b>A Max</b>	60.50 2.382
<b>B Max</b>	50.00 1.969
<b>C iso</b>	48x0.75
<b>D</b>	44.2f8 1.74f8
<b>E Max</b>	51.50 2.028
<b>F Max</b>	36.30 1.429
<b>H Max</b>	18.60 .732
<b>G Max</b>	56.00 2.205
<b>K Max</b>	10.70 .421

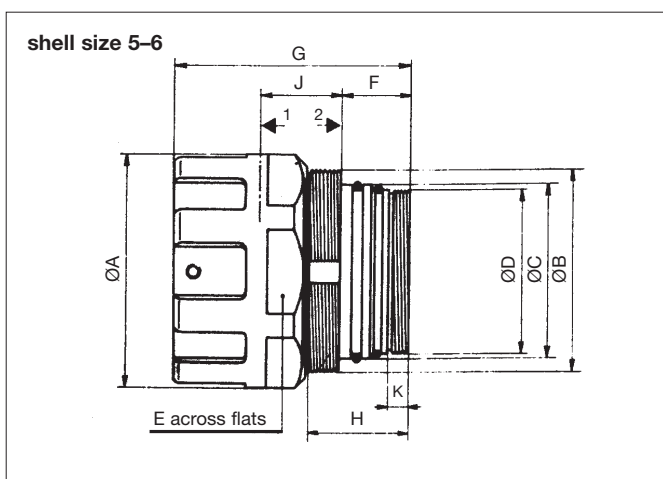

shell size	5	6
<b>A Max</b>	87.30 3.437	110.30 4.343
<b>B iso</b>	74x1.5	96x2
<b>C</b>	62.5 f7 2.46f7	82.5 f8 3.25f8
<b>D iso</b>	58x1.5	77x1.5
<b>E Max</b>	80.00 3.150	100.00 3.937
<b>F Max</b>	32.50 1.280	32.50 1.280
<b>J Max</b>	37.50 1.476	37.50 1.476
<b>G Max</b>	112.50 4.429	112.50 4.429
<b>K Max</b>	10.60 .417	10.60 .417
<b>H Max</b>	48.50 1.909	48.50 1.909

# 8810 Series



## Jam nut receptacles (series 10H)

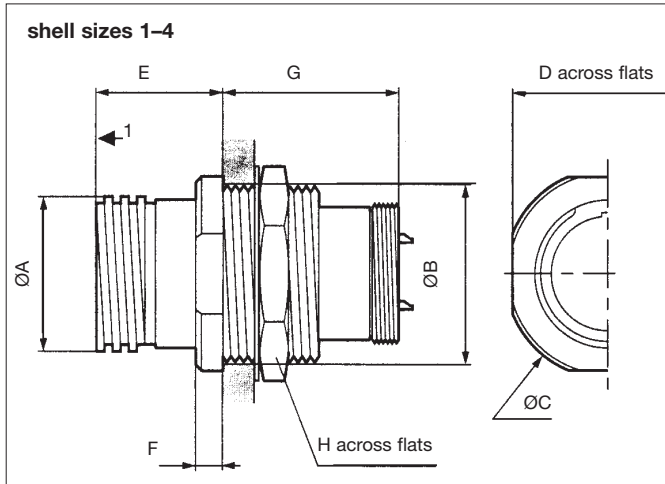

shell size	1	2	3	4
<b>A Max</b>	22.10 .870	25.10 .988	30.10 1.185	34.60 1.362
<b>B iso</b>	23.5x1	26.5x1	32x1	36.5x1
<b>C Max</b>	35.00 1.378	38.50 1.516	44.50 1.752	49.50 1.949
<b>D Max</b>	32.10 1.264	35.10 1.382	41.60 1.638	46.10 1.815
<b>E Max</b>	24.00 .945	24.00 .945	25.00 .984	26.00 1.024
<b>F Max</b>	5.00 .197	5.00 .197	5.00 .197	5.00 .197
<b>G Max</b>	34.50 1.358	34.50 1.358	34.50 1.358	34.50 1.358
<b>H Max</b>	27.00 1.063	30.00 1.181	36.00 1.417	41.00 1.614

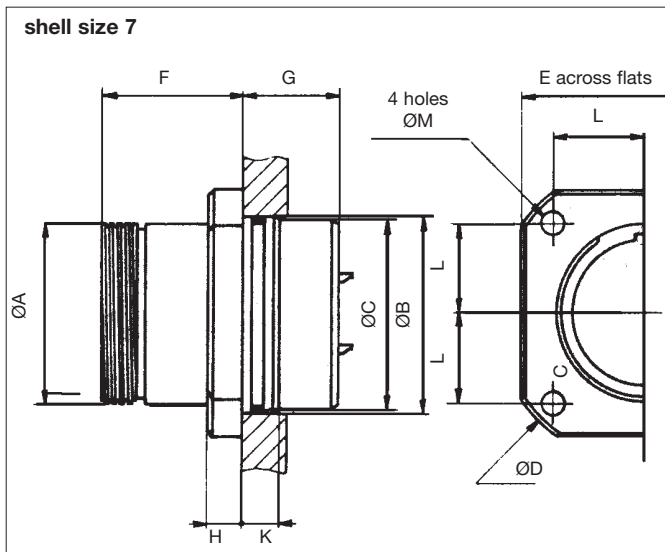

shell size	7
<b>A Max</b>	48.00 1.890
<b>B (H8)</b>	51.40 2.024
<b>C</b>	50.60 1.992
<b>D Max</b>	80.00 3.150
<b>E Max</b>	66.00 2.598
<b>F Max</b>	38.00 1.496
<b>G Max</b>	26.00 1.024
<b>H Max</b>	9.00 .354
<b>K Max</b>	9.50 .374
<b>L</b>	24.00 .945
<b>M</b>	5.70 .224

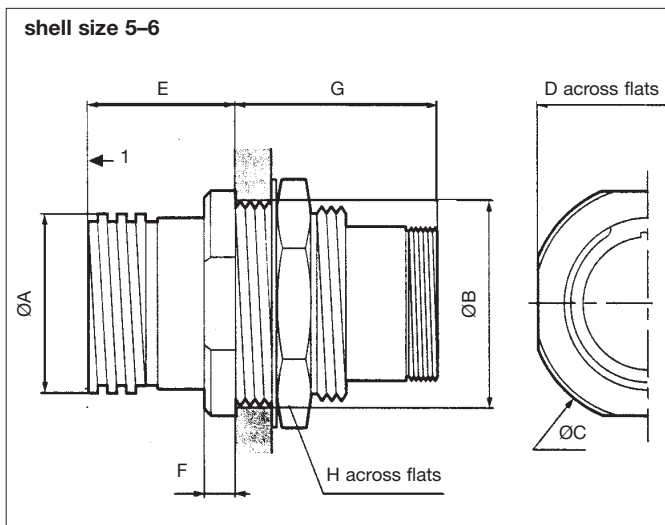

shell size	5	6
<b>A Max</b>	72.00 2.835	93 3.661
<b>B iso</b>	70x2	89x2
<b>C Max</b>	94.00 3.701	125.00 4.921
<b>D Max</b>	85.00 3.346	111.00 4.370
<b>E Max</b>	60.80 2.394	60.80 2.394
<b>F Max</b>	14.50 .571	14.50 .571
<b>G Max</b>	74.00 2.913	74.00 2.913
<b>H Max</b>	80.00 3.150	104.00 4.094

# 8810 Series



## Cable connecting receptacles (series 11H)

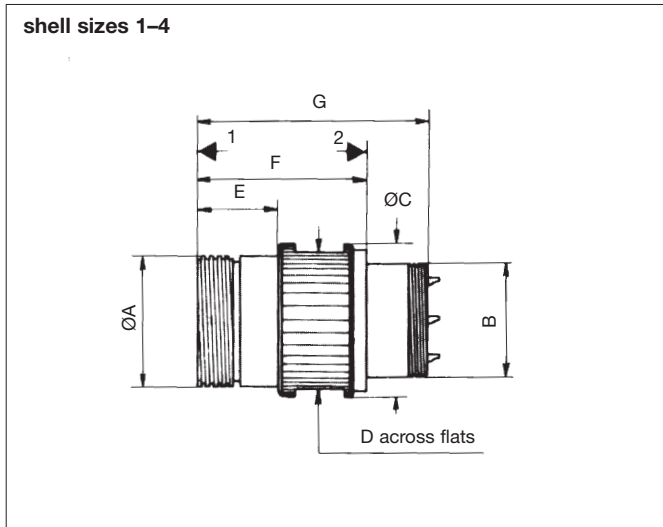

shell size	1	2	3	4
<b>A Max</b>	22.10 .870	25.10 .988	30.10 1.185	34.60 1.362
<b>B iso</b>	16.8x0.5	20x0.75	25.5x0.75	30x0.75
<b>C Max</b>	26.50 1.043	30.00 1.181	35.00 1.378	40.00 1.575
<b>D Max</b>	24.10 .949	27.10 1.067	32.10 1.264	36.10 1.421
<b>E Max</b>	19.00 .748	19.00 .748	20.00 .787	210 .827
<b>F Max</b>	42.10 1.657	42.10 1.657	43.10 1.697	44.10 1.736
<b>G Max</b>	58.10 2.287	58.10 2.287	59.10 2.327	60.10 2.366

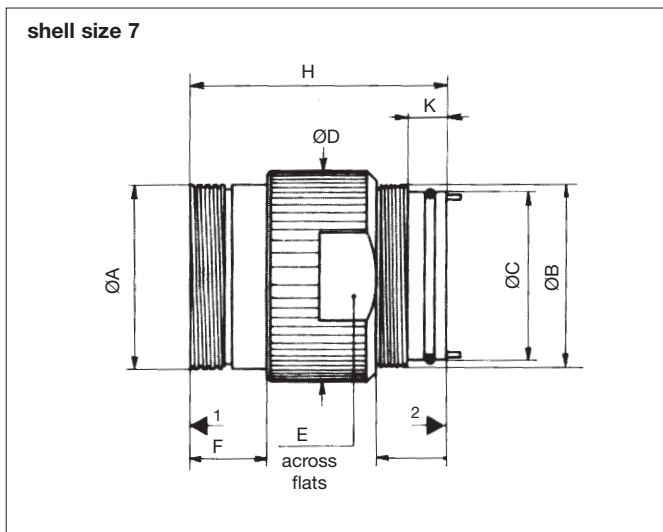

shell size	7
<b>A Max</b>	48.10 1.894
<b>B iso</b>	48x0.75
<b>C</b>	44.2f8 1.74f8
<b>D Max</b>	55.50 2.185
<b>E Max</b>	50.00 1.969
<b>F Max</b>	20.70 .815
<b>G Max</b>	18.60 .732
<b>H Max</b>	66.90 2.634
<b>K Max</b>	10.70 .421

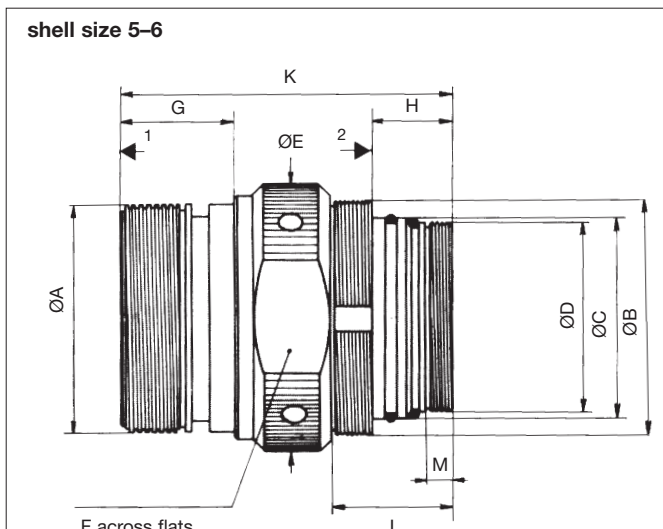

shell size	5	6
<b>A Max</b>	72.00 2.835	93.00 3.661
<b>B iso</b>	74x1.5	96x2
<b>C</b>	62.5f7 2.28f7	82.5f8 3.25f8
<b>D iso</b>	58x1.5	77x1.5
<b>E Max</b>	89.10 3.508	110.10 4.335
<b>F Max</b>	80.00 3.150	101.00 3.976
<b>G Max</b>	46.30 1.823	46.30 1.823
<b>H Max</b>	32.50 1.280	32.50 1.280
<b>K Max</b>	135.20 5.323	135.20 5.323
<b>L Max</b>	50.50 1.988	50.50 1.988
<b>M Max</b>	10.60 .417	10.60 .417

# 8810 Series



## Square flange receptacles (series 15H)

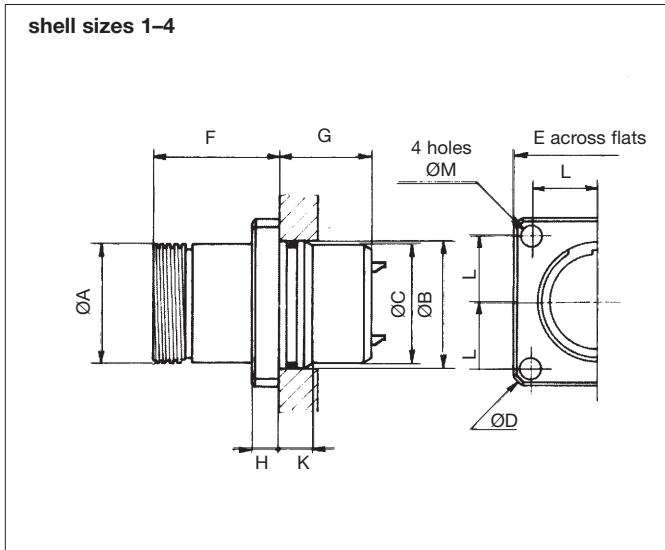

shell size	1	2	3	4
<b>A Max</b>	22.10 .870	25.10 .988	30.10 1.185	34.60 1.362
<b>B (H8)</b>	23.60 .929	26.60 1.047	32.10 1.264	36.60 1.441
<b>C Max</b>	22.90 .902	25.90 1.020	31.30 1.232	35.80 1.409
<b>D Max</b>	49.50 1.949	53.50 2.106	59.60 2.346	64.60 2.543
<b>E Max</b>	36.00 1.417	39.00 1.535	45.00 1.772	49.00 1.929
<b>F Max</b>	34.10 1.343	34.10 1.343	36.10 1.421	37.10 1.461
<b>G Max</b>	24.20 .953	24.20 .953	23.20 .913	23.20 .913
<b>H Max</b>	8.00 .315	8.00 .315	8.00 .315	8.00 .315
<b>K Max</b>	9.50 .374	9.50 .374	9.50 .374	9.50 .374
<b>L Max</b>	13.50 .531	15.00 .591	17.00 .669	19.00 .748
<b>M</b>	4.70 .185	4.70 .185	5.70 .224	5.70 .224

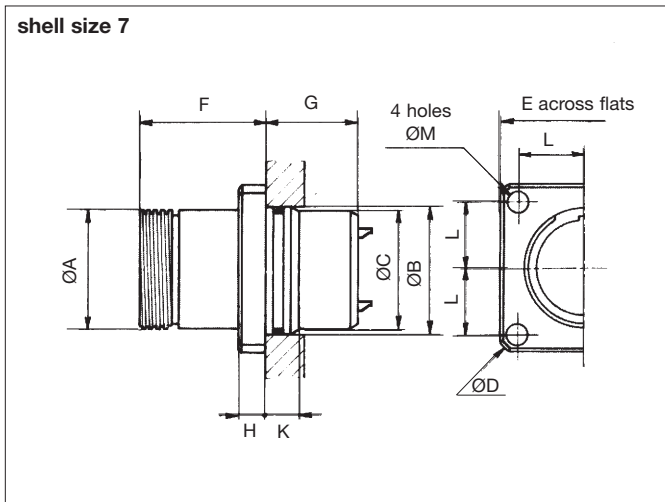

shell size	7
<b>A Max</b>	48.10 1.894
<b>B (H8)</b>	51.40 2.024
<b>C</b>	50.60 1.992
<b>D Max</b>	80.00 3.150
<b>E Max</b>	66.00 2.598
<b>F Max</b>	38.10 1.500
<b>G Max</b>	26.20 1.031
<b>H Max</b>	9.00 .354
<b>K Max</b>	9.50 .374
<b>L</b>	24.00 .945
<b>M</b>	5.70 .224

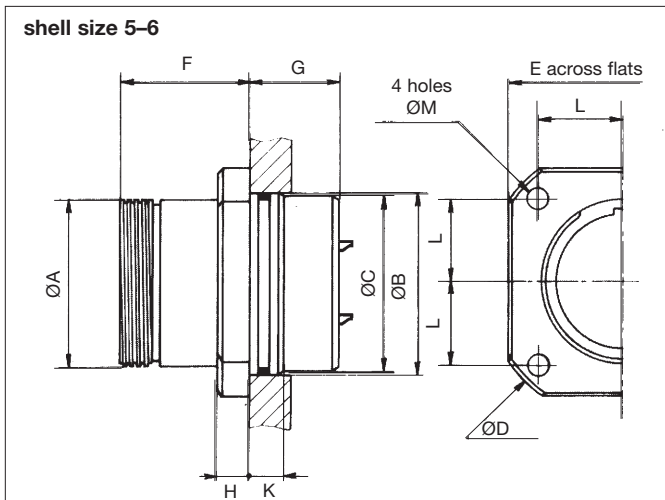

shell size	5	6
<b>A Max</b>	72.00 2.835	93.00 3.661
<b>B (H8)</b>	70.10 2.760	89.10 3.508
<b>C</b>	69.20 2.724	88.20 3.472
<b>D Max</b>	110.00 4.331	138.00 5.433
<b>E Max</b>	86.10 3.390	105.10 4.138
<b>F Max</b>	71.00 2.795	73.10 2.878
<b>G Max</b>	63.40 2.496	61.40 2.417
<b>H Max</b>	15.00 .591	15.00 .591
<b>K Max</b>	19.00 .748	19.00 .748
<b>L</b>	33.00 1.299	40.00 1.575
<b>M</b>	8.70 .343	10.70 .421

# 8810 Series



## Standard endbells

### Dimensions

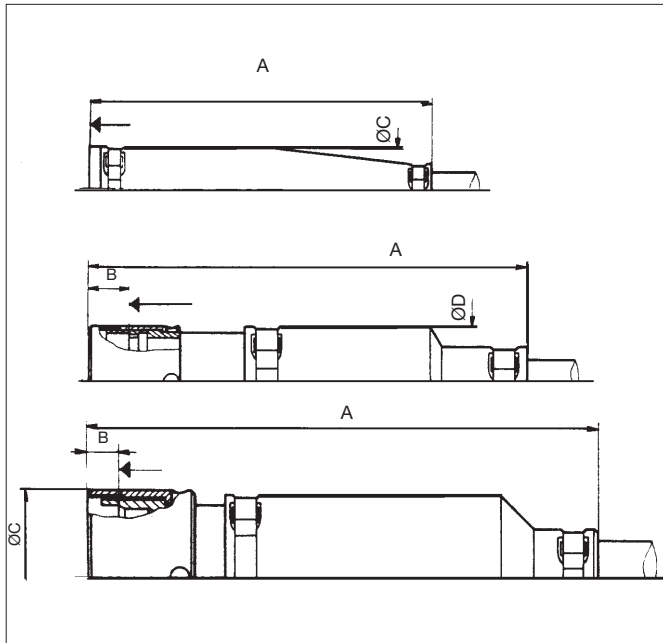

dimensions	shell size			
	1	2	3	4
<b>A Max</b>	105.00 4.134	119.00 4.685	135.00 5.315	149.00 5.866
<b>C Max</b>	26.00 1.024	29.40 1.157	35.70 1.406	40.70 1.602

dimensions	shell size
	7
<b>A Max</b>	210.00 8.268
<b>B Max</b>	18.60 .732
<b>C Max</b>	50.00 1.969

dimensions	shell size	
	5	6
<b>A Max</b>	230.00 9.055	280.00 11.024
<b>B Max</b>	14.90 .587	14.90 .587
<b>C Max</b>	79.00 3.110	99.00 3.898

### Ordering information

shell size	cable diameter	part number
1	7.8-8.8	8810-13-078-088
1	8.7-9.7	8810-13-087-097
1	9.5-10.5	8810-13-095-105
1	10.5-11.5	8810-13-105-115
2	9.3-10.3	8810-23-093-103
2	10.3-11.3	8810-23-103-113
2	11.0-12.0	8810-23-110-120
2	12.0-13.0	8810-23-120-130
3	9.5-11.0	8810-33-095-110
3	11.0-12.5	8810-33-110-125
3	12.5-14.0	8810-33-125-140
3	14.0-15.5	8810-33-140-155
4	11.2-12.7	8810-43-112-127
4	12.7-14.2	8810-43-127-142
4	14.0-15.5	8810-43-140-155
4	15.5-17.0	8810-43-155-170

shell size	cable diameter	part number
7	18.0-20.0	8810-73-180-200
7	20.0-22.0	8810-73-200-220
7	22.0-24.0	8810-73-220-240
7	24.0-26.0	8810-73-240-260
7	26.0-28.0	8810-73-260-280
5	15.0-20.0	8810-53-150-200
5	20.0-25.0	8810-53-200-250
5	25.0-30.0	8810-53-250-300
5	30.0-35.0	8810-53-30-350
6	22.0-28.0	8810-63-220-280
6	28.0-34.0	8810-63-280-340
6	34.0-40.0	8810-63-340-400
6	40.0-45.0	8810-63-400-450
6	45.0-50.0	8810-63-450-500

Adapters are available to enable next larger shell size clamp to be fitted - Please consult us.

In shell size 1 to 7  
Custom design end-bells are developed for other cable dimensions, please consult us



# 8810 Series



## Longitudinally sealed Endbells Dimensions

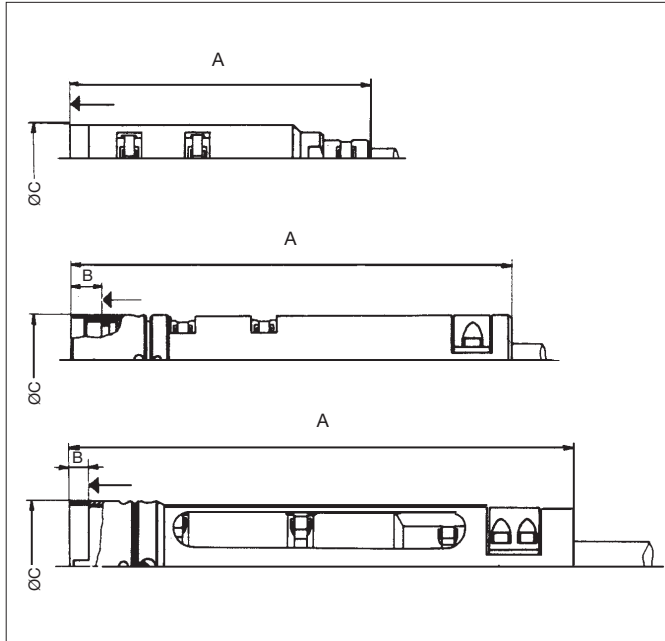

dimensions	shell size			
	1	2	3	4
<b>A Max</b>	146.00 5.748	153.00 6.024	160.00 6.299	167.00 6.575
<b>B Max</b>	–	–	–	–
<b>C Max</b>	24.70 .972	28.20 1.110	33.70 1.327	38.20 1.504

dimensions	shell size	
	7	
<b>A Max</b>	2430 9.567	
<b>B Max</b>	17.90 .705	
<b>C Max</b>	50.00 1.969	

dimensions	shell size	
	5	6
<b>A Max</b>	383.00 15.079	392.00 15.433
<b>B Max</b>	15.00 .591	15.00 .591
<b>C Max</b>	80.10 3.154	90.00 3.898

## Ordering information

shell size	cable diameter	part number	
1	7.8-8.8	8810-13-	078-088
1	8.7-9.7	8810-13-	087-097
1	9.5-10.5	8810-13-	095-105
1	10.5-11.5	8810-13-	105-115
2	9.3-10.3	8810-23-	093-103
2	10.3-11.3	8810-23-	103-113
2	11.0-12.0	8810-23-	110-120
2	12.0-13.0	8810-23-	120-130
3	9.5-11.0	8810-33-	095-110
3	11.0-12.5	8810-33-	110-125
3	12.5-14.0	8810-33-	125-140
3	14.0-15.5	8810-33-	140-155
4	11.2-12.7	8810-43-	112-127
4	12.7-14.2	8810-43-	127-142
4	14.0-15.5	8810-43-	140-155
4	15.5-17.0	8810-43-	155-170

shell size	cable diameter	part number	
7	18.0-20.0	8810-73-	180-200
7	20.0-22.0	8810-73-	200-220
7	22.0-24.0	8810-73-	220-240
7	24.0-26.0	8810-73-	240-260
7	26.0-28.0	8810-73-	260-280
5	15.0-20.0	8810-53-	150-200
5	20.0-25.0	8810-53-	200-250
5	25.0-30.0	8810-53-	250-300
5	30.0-35.0	8810-53-	30-350
6	22.0-28.0	8810-63-	220-280
6	28.0-34.0	8810-63-	280-340
6	34.0-40.0	8810-63-	340-400
6	40.0-45.0	8810-63-	400-450
6	45.0-50.0	8810-63-	450-500

insert appropriate contact number - see page contacts layouts.

insert appropriate contact number - see page contacts layouts.

Adapters are available to enable next larger shell size clamp to be fitted

For shell size 1 to 7  
Custom design endbells are developed for other cable OD dimensions, please consult us.  
For shell size 4 with a cable OD >17mm 0.669, the adapter 8810 6524 has to be used.